

LARGE HORIZONTAL MACHINING CENTER

# GBH SERIES

**1000 · 1250 · 1250W**



**SUZHOU GUDWAY CNC EQUIPMENT CO.,LTD**

Add : No. 21 Xiexin Road, New District, Suzhou City, Jiangsu Province, China.

Tel : +86-0512-65580060

Email : [info@gudwaycnc.com](mailto:info@gudwaycnc.com)

Web : <http://www.gudwaycnc.com>

# GBH 1000 · 1250 · 1250W

A twin pallet horizontal machining centre designed for processing large workpieces. A wide variety of machining applications can be carried out with the 1000/1250mm pallet size and optional W axis capability. The heavy duty box guideways, high torque gearbox spindle and minimum non-cutting time will provide users with a high level of productivity and added value.



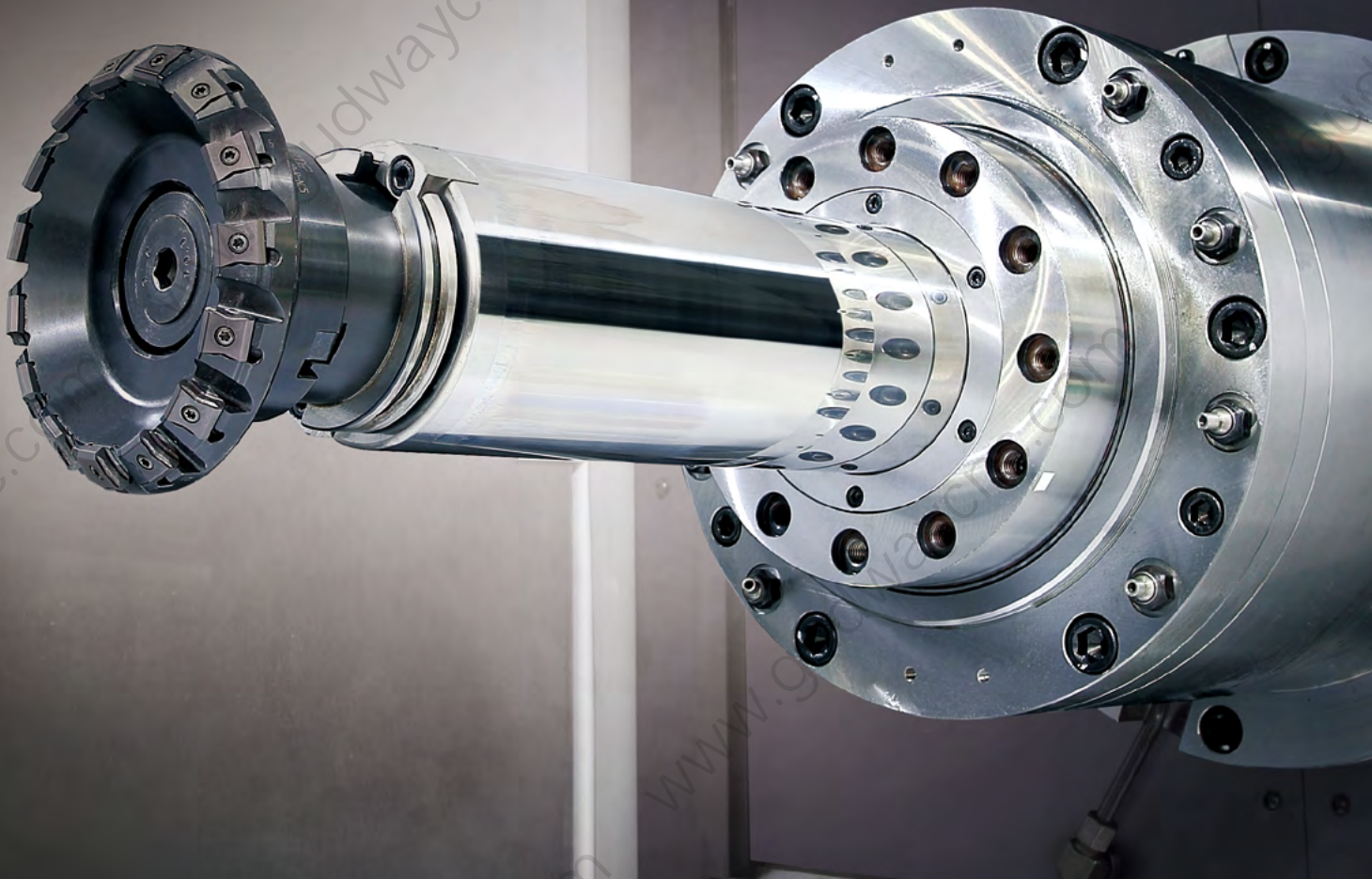

### IMPROVED PRODUCTIVITY WITH HIGH PERFORMANCE SPECIFICATIONS

- High torque gearbox spindle, box-type guideways, and high rigidity cast structure achieves high productivity.

### GENERAL TYPE AND OPTIONAL W AXIS APPLICATIONS

- A wide variety of large workpieces can be handled due to the machine's large capacity and optional W axis for long boring applications.

### READY FOR AUTOMATION WITH STANDARD PALLET CHANGE SYSTEM

- The shuttle-type pallet changer satisfies the needs for long-term operation and automation.



# BASIC STRUCTURE

High rigidity bed supports high accuracy.

## Large Horizontal Machining Center

Designed for large workpieces requiring heavy duty cutting performance, the GBH1000/1250/1250W offer the solution for various requirements.

### Travel distance (X / Y / Z axis)

GBH 1000

**2100 / 1250 / 1250** mm

82.7 / 49.2 / 49.2 inch

GBH 1250

**2100 / 1500 / 1500** mm

82.7 / 59.1 / 59.1 inch

### Travel distance (X / Y / Z / W axis)

GBH 1250W

**2100 / 1400 / 1400 / 300** mm

82.7 / 55.1 / 55.1 / 11.8 inch

### Rapid traverse rate (X / Y / Z axis)

GBH 1000 / GBH 1250

**24 / 24 / 24** m/min

944.9 / 944.9 / 944.9 ipm

### Rapid traverse rate (X / Y / Z / W axis)

GBH 1250W

**24 / 24 / 24 / 6** m/min

944.9 / 944.9 / 944.9 / 236.2 ipm

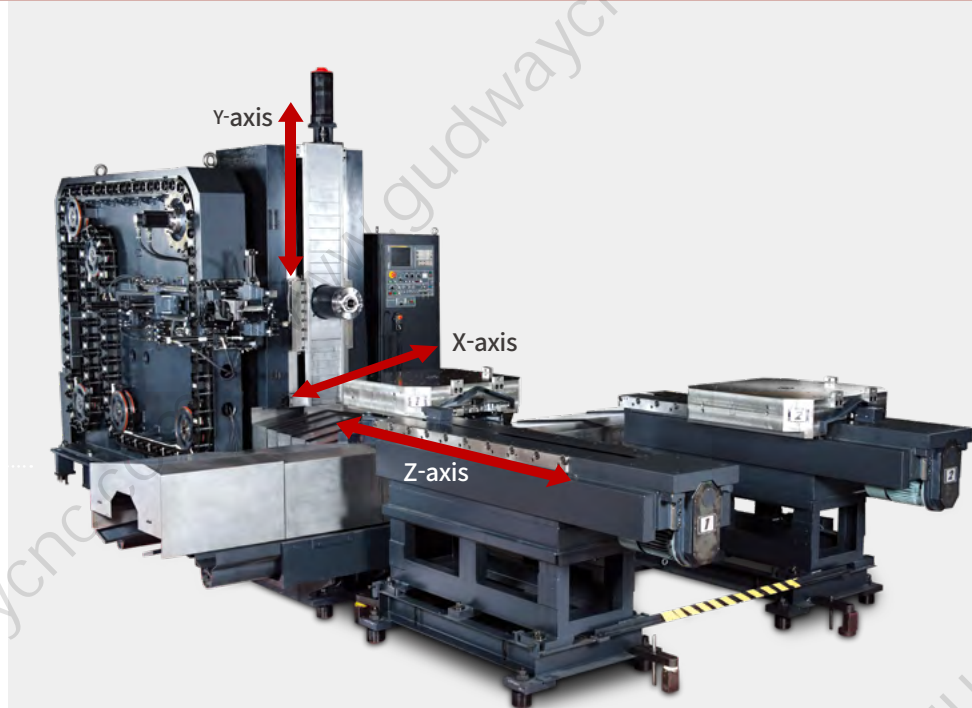

GBH 1000 / 1250

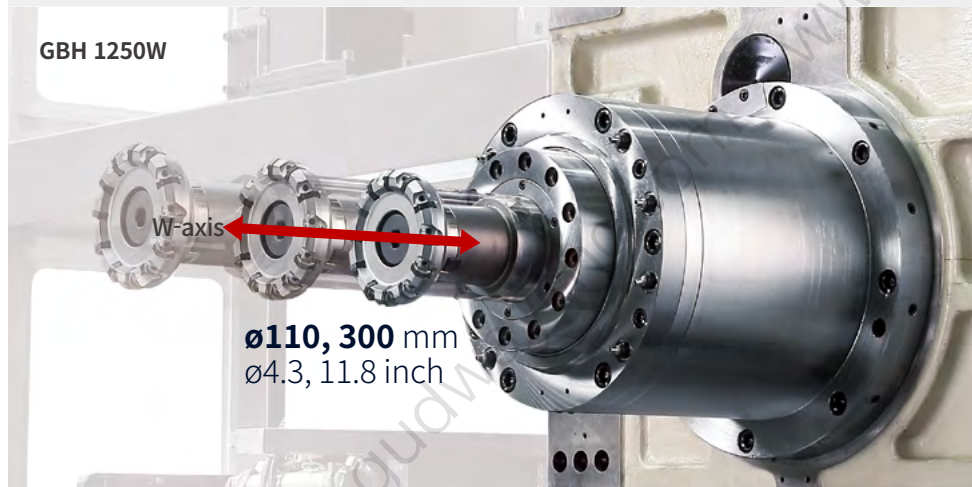

GBH 1250W

## Stable High-rigidity Axis Structure

All the linear axes are driven by high precision preloaded ballscrews to minimise thermal error. They are coupled directly to the absolute-type servo motor to optimise accuracy.

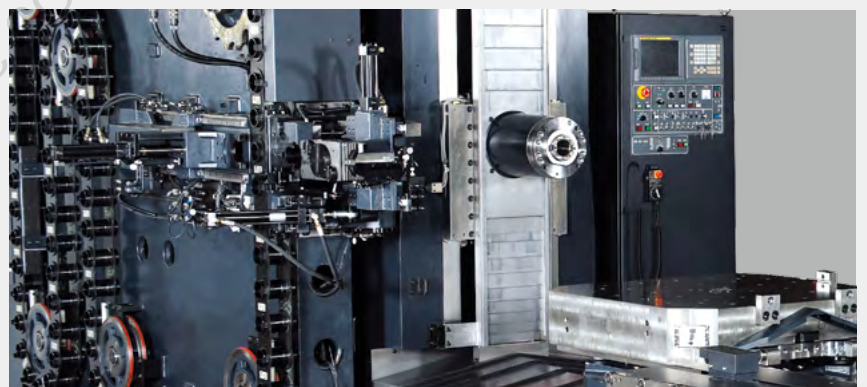

# SPINDLE

Gearbox driven spindle realizes high productivity.

## Gearbox Spindle

High torque spindle, dual contact tool system, and spindle cooling system adopted as standard realize high stability and reliability.

### Max. spindle speed

GBH 1000 / GBH 1250

**6000** r/min

**6000 / 8000** r/min option

GBH 1200W

**3000** r/min

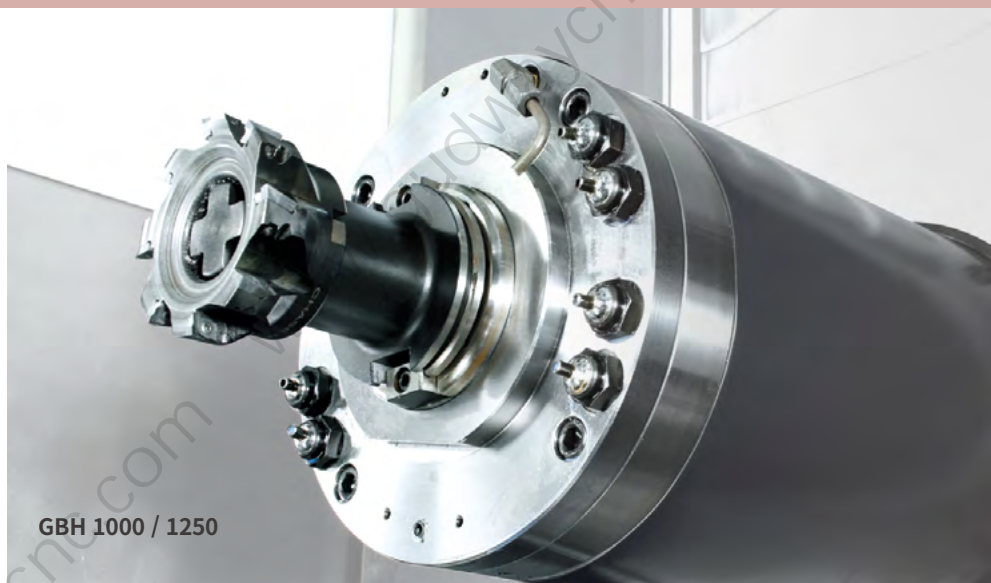

GBH 1000 / 1250

## Spindle Cooling

Adopted as a standard feature, the oil cooler system minimizes thermal error over an extended time of operation the oil cooler system minimises thermal error over an extended period of operation.

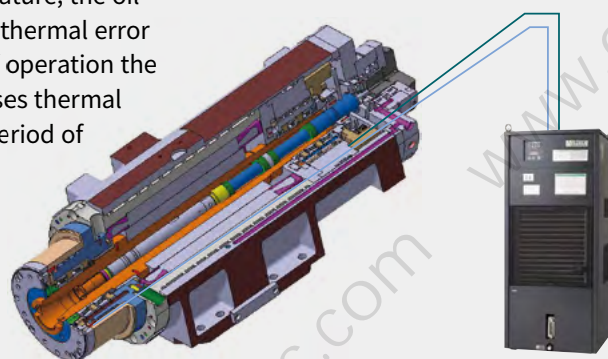

Item	Unit	GBH 1000 / 1250	GBH 1250W
Max. spindle speed	r/min	6000 {6000, 8000}	3000
Spindle motor power (30min. / Cont.)	kW (Hp)	26 / 22 {37 / 30, 26 / 22} (34.9 / 29.5 {49.6 / 40.2, 34.9 / 29.5})	45 / 37 (60.3 / 49.6)
Max. spindle torque	N·m (ft·lb)	1989.4 {3687 / 1410} (1468.2 {2721.0 / 1040.6})	1910 (1409.6)

{ } : option

# MAGAZINE

Reliability is further improved with the adoption of servo motors and the tool storage capacity can be extended up to 316 tools.

## Tool-to-Tool ( T-T-T )

GBH 1000 / GBH 1250

**10** s

GBH 1250W

**12** s

## Tool storage capacity

**60** ea

90 / 120 / 196 / 256 /

316 ea option

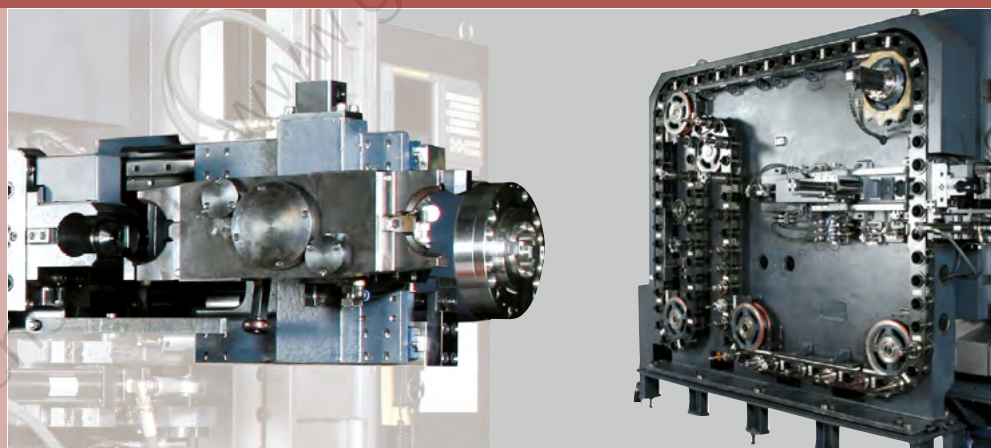

Item	Unit	GBH 1000	GBH 1250	GBH 1250W
Tool storage capacity	ea	60 {90 / 120, 196 / 256 / 316 (MATRIX)}		
Tool-to-Tool	sec	10		12
Max. tool diameter (Neighboring pot empty)	mm (inch)	130 (300) (5.1 (11.8))		
Max. tool length	mm (inch)	650 (25.6)	650 {800*} (25.6 {31.5'})	700 (27.6)
Max. tool weight	kg (lb)	30 (66.1)		

\* In case of GBH 1250 with Max. Workpiece diameter 2000 mm spec.

# TABLE | CUTTING PERFORMANCE

The table capacity is suitable for large workpieces .

## Pallet size

GBH 1000

**1000 x 1000** mm  
39.4 x 39.4 inch

**1250 x 1000** mm option  
49.2 x 39.4 inch

GBH 1250 / GBH 1200W

**1250 x 1250** mm  
49.2 x 49.2 inch

**1250 x 1000** mm option  
49.2 x 39.4 inch

## Max. work size

GBH 1000

**2000 x 1475** mm  
78.7 x 58.1 inch

GBH 1250 / GBH 1200W

**2000 x 1725** mm  
18.7 x 67.9 inch

**2300 x 1725** mm\* option  
90.6 x 67.9 inch

\* It is non circular

## Loading capacity

GBH 1000 / GBH 1250

**3000** kg 6613.8 lb  
**5000** kg 11023.0 lb option

GBH 1200W

**5000** kg 11023.0 lb

The shuttle-type, automatic pallet changer as standard specification improves productivity.

Circular max. work size

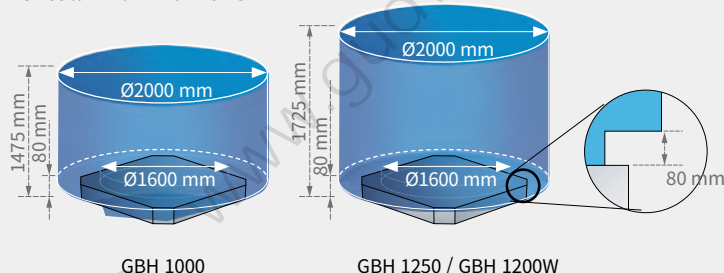

Non circular max. work Size

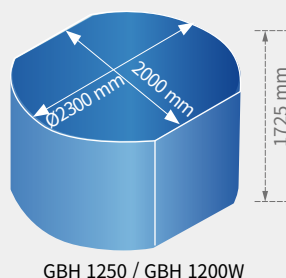

## Machining Performance

GBH 1250W

Face mill (material : SM45C / W-axis : 300 mm (11.8 inch))

Tool mm (inch)	Spindle speed r/min	Feed rate mm/min (ipm)	Cutting width mm (inch)	Cutting depth mm (inch)	Chip removal rate cm <sup>3</sup> /min (inch <sup>3</sup> )
D125	360	300 (11.8)	80 (3.1)	1.7 (0.067)	40.8 (2.5)

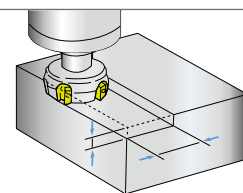

Face mill (material : SM45C / W-axis : 0 mm (0 inch))

Tool mm (inch)	Spindle speed r/min	Feed rate mm/min (ipm)	Cutting width mm (inch)	Cutting depth mm (inch)	Chip removal rate cm <sup>3</sup> /min (inch <sup>3</sup> )
D125	300	1680 (66.1)	100 (3.9)	7 (0.3)	1176 (71.8)
	300	1400 (55.1)	100 (3.9)	8 (0.3)	1120 (68.3)
	300	1300 (51.2)	100 (3.9)	9 (0.4)	1170 (71.4)

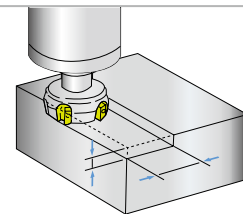

U-drill

Tool mm (inch)	Spindle speed r/min	Feed rate mm/min (ipm)	Cutting depth mm (inch)
D85 (D3.3)	560	165 (6.5)	50 (2.0)
D120 (4.7)	380	77 (3.0)	50 (2.0)

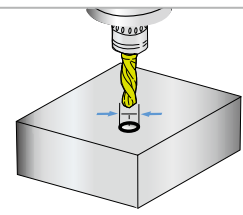

Tap

Tool mm (inch)	Spindle speed r/min	Feed rate mm/min (ipm)	Cutting depth mm (inch)
M48 x 5 (M1.9 x 0.2)	100	500 (19.7)	45 (1.8)

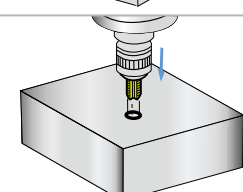

The results, indicated in this catalogue are provides as example. They may not be obtained due to differences in cutting conditions and environmental conditions during measurement.



# STANDARD | OPTIONAL SPECIFICATIONS

A range of options is available to suit individual requirements.

Description	Features	GBH1000	GBH1250	GBH1250W
PALLET TYPE	0.001 DEGREE			
	1 DEGREE	●	●	●
NO. OF PALLETS	2 EA	●	●	●
	2 EA + 1 SPARE PALLET	○	○	○
	2 EA + 2 SPARE PALLETS	○	○	○
	2 EA + 3 SPARE PALLETS	○	○	○
	2 EA + 4 SPARE PALLETS	○	○	○
	6 PALLETS MAGAZINE STATION - PMG	○	○	○
PALLET CHECK SYSTEM	AIR LIMIT SENSING	○	○	○
	1000 X 1000 MM	●	○	○
PALLET SIZE	1250 X 1000 MM	○	○	○
	1250 X 1250 MM	X	●	●
REFERENCE OF WORKPIECE SETTING	CENTER BUSH	○	○	○
	120 EA	○	○	○
TOOL STORAGE CAPACITY	196 EA	○	○	○
	60 EA	●	●	●
	90 EA	○	○	○
AUTO TOOL MEASURING DEVICE	ENCODER NEEDLE TYPE_BK MIKRO	○	○	○
	OMRON LIMIT SWITCH TYPE	○	○	○
	RMI-Q_ONLY_RENISHAW	○	○	○
	TS27R_RENISHAW	○	○	○
AIR	AIR BLOWER	○	○	X
	AIR GUN	○	○	○
OIL SKIMMER	BELT TYPE	○	○	○
COOLANT	COOLANT GUN	○	○	○
	SHOWER COOLANT	○	○	○
THROUGH SPINDLE COOLANT	1.5 kW_2.0 MPA	○	○	○
	1.5 kW_2.0 MPA_CYCLON FILTER	○	○	○
	1.5 kW_3.0 MPA_COOLJET BAG FIL	○	○	○
	3.7 kW_7.0 MPA_BAG FILTER	○	○	○
	3.7 kW_7.0MPA_PAPER ROLL FILTER	○	○	○
	4.0 kW_2.0 MPA	○	○	○
	3.0 kW_3.0 MPA_CYCLON FILTER	○	○	○
	5.5 kW_7.0 MPA_DUAL BAG FILTER	○	○	○
7.5 kW_7.0 MPA_CYCLON FILTER	○	○	○	
AUTO WORKPIECE MEASURING DEVICE	OMP60_RENISHAW	○	○	○
	RMP60_RENISHAW	○	○	○
CALIBRATION BLOCK	CALIBRATION BLOCK	○	○	○
	FORKLIFT_380L	○	○	○
CHIP CONVEYOR	ROTATION_380L	○	○	○
	HINGED BELT_LEFT SIDE	○	○	○
	MAGNETIC SCRAPER_LEFT SIDE	○	○	○
LINEAR SCALE (X/Y/Z AXIS)	ABSOLUTE PULSE CODER	○	○	○
MIST COLLECTOR	2.2 KW_NONE WATER SOLUBLE	○	○	○
	2.2 KW_WATER SOLUBLE	○	○	○
SAFETY SENSOR FOR OPERATOR	ARRAY SENSOR	○	○	○
TEST BAR	TEST BAR GAUGE	○	○	○
WORK LOCATING CONFIRMATION	AIR LIMIT SENSING_2 PORT	○	○	○
AIR CONDITIONER	AIR CONDITIONER	○	○	○
AUTOMATIC POWER OFF	AUTOMATIC POWER OFF	○	○	○
AUTOMATIC POWER ON	AUTOMATIC POWER ON	○	○	○
ELECTRIC CABINET LIGHT	ELECTRIC CABINET LIGHT	○	○	○
FASTEMS FMS INTERFACE	FASTEMS FMS INTERFACE	○	○	○
MPG	3 MPG_PORTABLE TYPE	○	○	○
	SINGLE PALLET	○	○	○
CUSTOMIZED SPECIAL OPTION	HYD. FIXTURE 2X2	○	○	○
	X, Z AXIS SLIDE COVER CHIP FLUSHING	○	○	○
	TOOL LENGTH 800MM	X	○	X
	AUTO DOOR HEIGHT (1725mm → 2000mm)	X	○	X
	15K SPINDLE HEAD	X	○	X

\* Please contact GUDWAY for detailed specification information.

● Standard ○ Optional X Not applicable

\*When using a semi-synthetic type or synthetic type, contact our sales representative or service center in advance.

 **Fire Safety Precautions** | There is a high risk of fire when using non-water-soluble cutting fluids, processing flammable materials, neglecting the controlled and careful use of coolants and modifying the machine without the consent of the manufacturer. Always check the SAFETY GUIDELINES carefully before using the machine.

# PERIPHERAL EQUIPMENT

## Chip Conveyor



## Measurement Systems

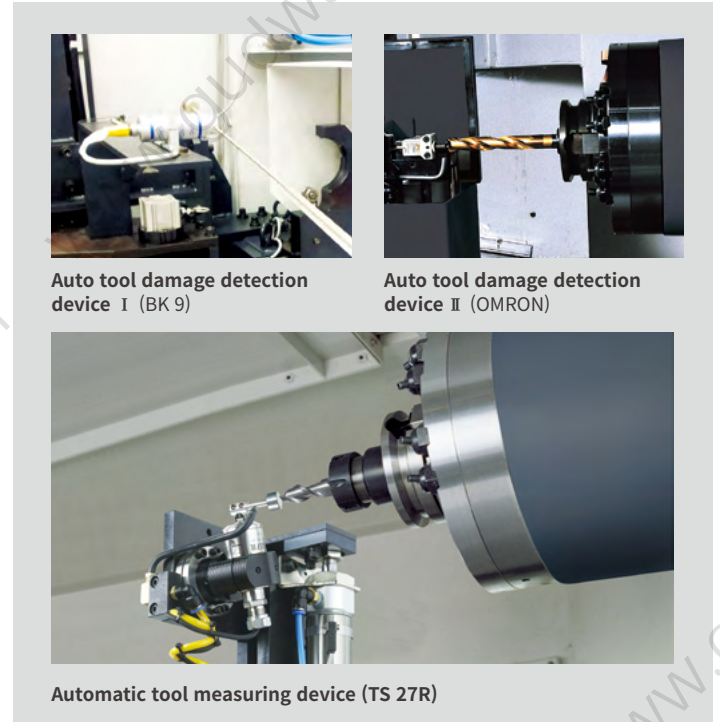

## Environment Friendly Devices



## Cutting Oil Cooling System

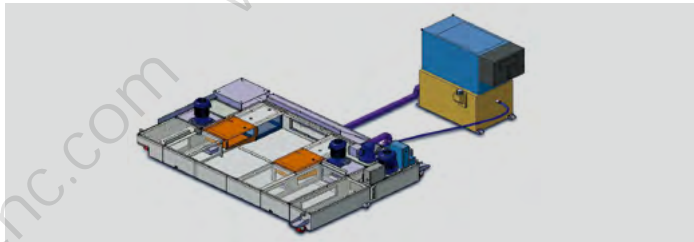

## Linear Scale Feedback System



## Chip Disposal System





# MULTI PALLET SYSTEM

## PMG (Pallet Magazine)

The PMG system is composed of a rotating pallet pool storage unit and a feed mechanism to transfer the pallet to and from the machine working area. In addition, a pallet can be transferred to a separate setup station where the operator has allround access for loading the workpiece.

### Features

- Conventional multi pallet changer round type
- Available large volume workpiece
- Driven by hydraulic unit
- Stable pallet changing unit
- Pallet scheduling operation (1-Path, PMC control)

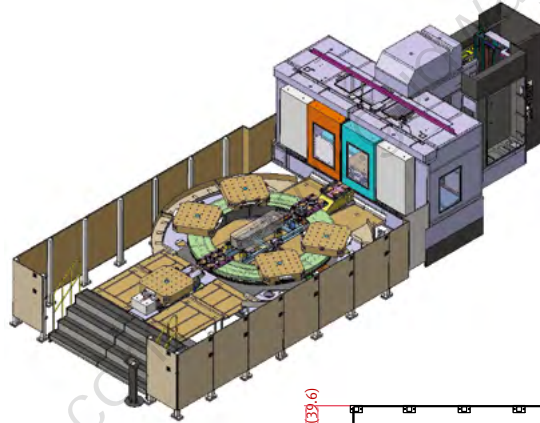

### External Dimensions

Unit : mm (inch)

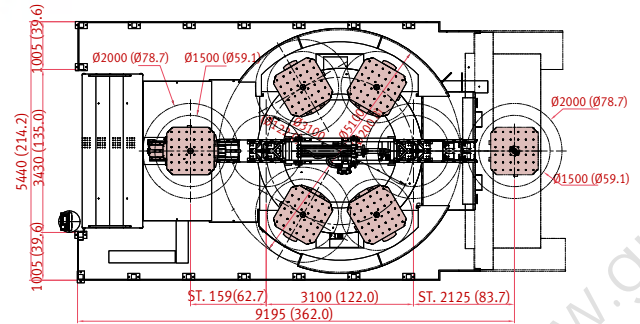

Available Model		GBH 1000	GBH 1250	GBH 1250W
Pallet Dimension	mm (inch)	1000 x 1000 (39.4 x 39.4), 1250 x 1000 (49.2 x 39.4)		
Workpiece Diameter	mm (inch)	1500 (59.1) {2000 (78.7), closed pallet need to be empty}		
Workpiece Height	mm (inch)	1475 (58.1)	1725 (67.9)	
Workpiece Weight	kg (lb)	3000 (6613.8)		
Magazine type		Round type		
Operation		Pallet scheduling operation (1-Path, PMC control)		
Pallet Drive Device		HYDRAULIC MOTOR & CHAIN		
Hydraulic Power Unit	kW (Hp)	7.5 (10.1)		

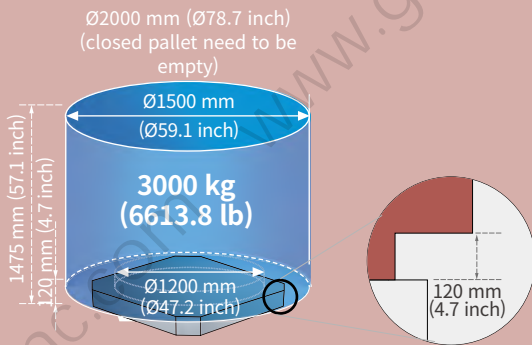

## Single pallet system

Space can be reduced by Single-pallet system.

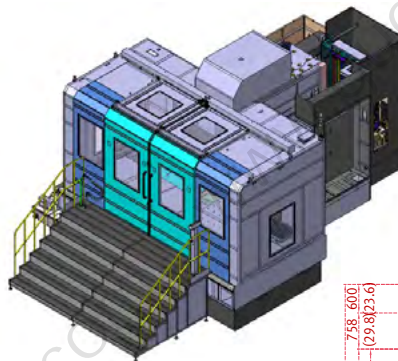

### External Dimensions

Unit : mm (inch)

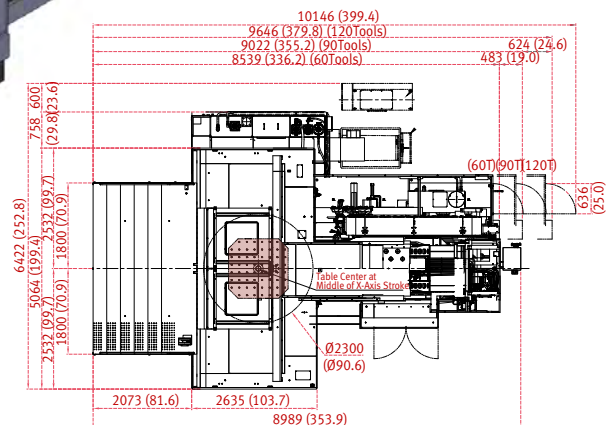

Description		GBH 1000	GBH 1250	GBH 1250W
Max work-piece size	mm (inch)	2000 x 1475 (78.7 x 58.1)		2300 x 1725

\* This layout is for GBH1250 Single pallet

# FANUC 31i PLUS

Fanuc 31i Plus maximizes customer productivity and convenience.

## 15" Touch screen + New OP

GUDWAY Fanuc 31iB/B5 Plus' operation panel enhances operating convenience by incorporating common-design buttons and layout. It features a Qwerty keyboard for fast and easy data input and operation.

## Fanuc 31i Plus

- 15-inch color display
- Intuitive and user-friendly design

## USB and PCMCIA card QWERTY keyboard

- EZ-Guide i standard
- Ergonomic operator panel
- 4MB Memory
- Hot keys
- Enhance AICC BLOCK
- Touch pen provided as standard



## iHMI touchscreen

iHMI provides an intuitive interface that uses a touchscreen for quick and easy operation.

## Range of applications

Providing various applications related to planning, machining, improvement and utility, for customer convenience.

# NUMERIC CONTROL SPECIFICATIONS

# FANUC

	Item	Specifications	F31iB PLUS
			GBH1000 / GBH1250 / 1250W
Controlled axis	Controlled axes		4 (X,Y,Z,B)
	Simultaneously controlled axes		4 axes
	Additional controlled Axis	Add 1 Axis (5th Axis)	●
Data input/output	Fast data server		○
	Memory card input/output		●
	USB memory input/output		●
	Large capacity memory(2GB)*2	Note *2) Available Option only with 15" Touch LCD (iHMI Only)	○
Interface function	Embedded Ethernet		●
	Fast Ethernet		○
	Enhanced Embedded Ethernet function		●
Operation	DNC operation	Included in RS232C interface.	●
	DNC operation with memory card		●
	Workpiece coordinate system	G52 - G59	●
Program input	Addition of workpiece coordinate system	G54.1 P1 X 48 (48 pairs)	●
	Tool number command		●
	Tilted working plane indexing command	G68.2 TWP	○
	AI contour control I	G5.1 Q_, 40 Blocks	X
Feed function	AI contour control II	G5.1 Q_, 200 Blocks	X
	AI contour control II	G5.1 Q_, 600 Blocks	●*
	AI contour control II	G5.1 Q_, 1000 Blocks	○*
	High smooth TCP		X
	EZ Guidei (Conversational Programming Solution)		●
Operation Guidance Function	iHMI with Machining Cycle	Note *1) Only with 15" Touch LCD standard	●
	EZ Operation package		●
Setting and display	CNC screen dual display function		●
Network	FANUC MT Connect		⊕
	FANUC OPC UA		⊕
Others	Display unit	15" color LCD	X
		15" color LCD with Touch Panel	●
		640M(256KB) _500 programs	X
		1280M(512KB) _1000 programs	X
		2560M(1MB) _1000 programs	X
		5120M(2MB) _1000 programs	X
		10240M(4MB) _1000 programs	●
		20480M(8MB) _1000 programs	○
		2560M(1MB) _2000 programs	○
		5120M(2MB) _4000 programs	○
	10240M(4MB) _4000 programs	○	
20480M(8MB) _4000 programs	○		
Part program storage size & Number of registerable programs			

Network: FANUC MTConnect and FANUC OPC UA available.

\* The number of look-ahead blocks may be changed or limited depending on the peripheral device or the configuration of the internal NC system.

● Standard ○ Optional X Not Available ⊕ Available

# EZ WORK

The software developed by GUDWAY features numerous functions designed for convenience and ease of operation.

## EZ work

The EZ work package delivers speed and efficiency. This menu-driven innovation not only helps customers reduce setup times, but also simplifies common tasks and procedures, reducing the potential for errors. EZ work reduces operating time, protects machinery, enhances quality and speeds up maintenance interventions.

## Tool support functions



### Tool management I

- Tool magazine control
- Tool state display
- Fastems Tool Add/Remove Function **option**



### Tool management II **option**

- Tool magazine control
- Tool life management
- Tool life prediction
- Tool state control
- Balluff Tool ID function



### Tool load monitor **option**

- Detection of tool damage
- Detection of abnormalities during operation
- Detection of no-load air cutting

## Productivity improvement functions



### Adaptive Feed Control

Function to control feedrate so that the cutting can be carried out at a constant load



### APC Setting Screen

A simple automation function that supports automatic processing of the next pallet by setting the processing program for each pallet of the equipment including APC in advance

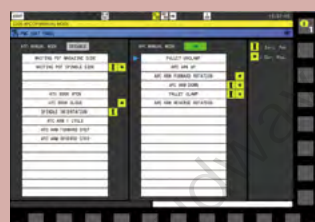

### PMC Soft Panel Switch

Manual operations that occur continuously in each stages for APC,ATC change command

## Operation support, Help desk functions

### Operation rate

- Measure various machine operating rate
- Support 3 shift operation
- calculate and save 30 days operating rate
- Show data for a specific period

### Pattern Cycle

A function to automatically create frequently used part programs.

### Renishaw GUI

Renishaw tool length measuring and compensate function

### Spindle Warm Up

A function that assists spindle warm-up for spindle life when the spindle has not been used for a certain period of time



## GBH 1000 / 1250

### 6000 r/min

Spindle motor power: **26 / 22 kW**  
34.9 / 29.5 Hp

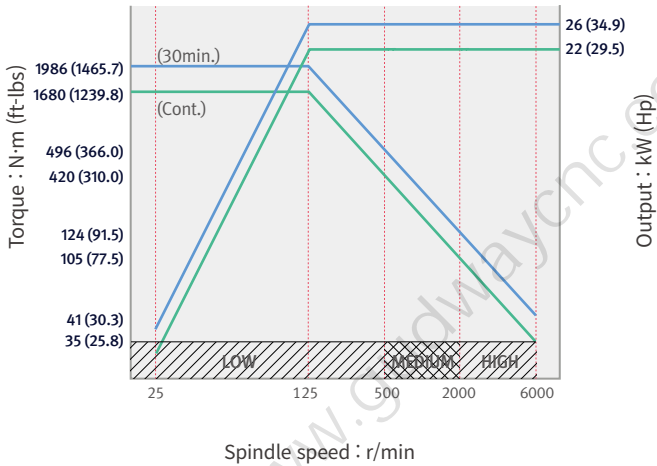

### 6000 r/min option

Spindle motor power: **37 / 30 kW**  
49.6 / 40.2 Hp

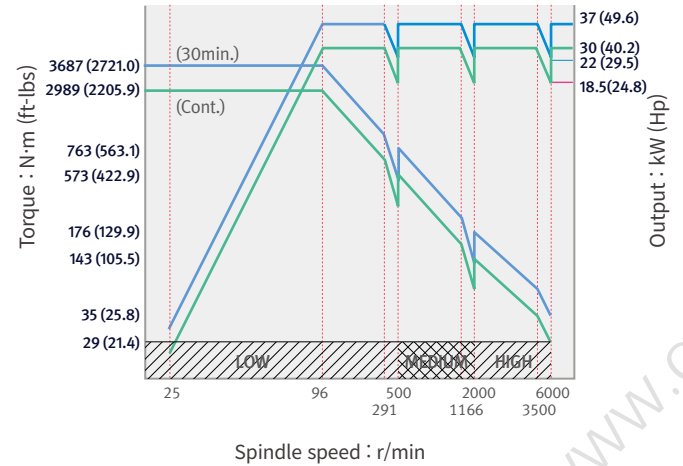

### 8000 r/min option

Spindle motor power: **26 / 22 kW**  
34.9 / 29.5 Hp

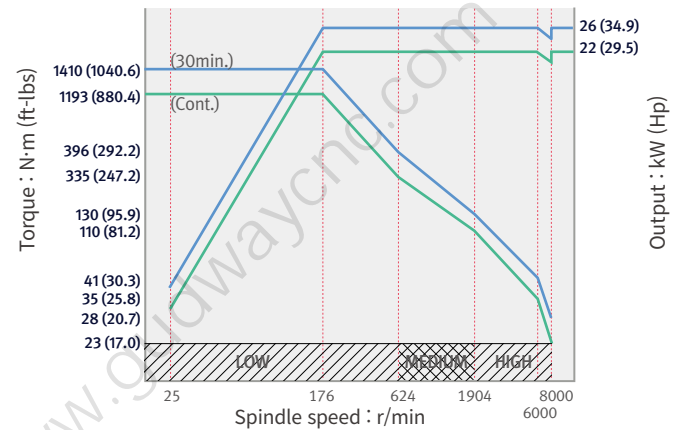

## GBH 1250W

### 3000 r/min

Spindle motor power: **45 / 37 kW** (30min. / Cont.)  
60.3 / 49.6 Hp

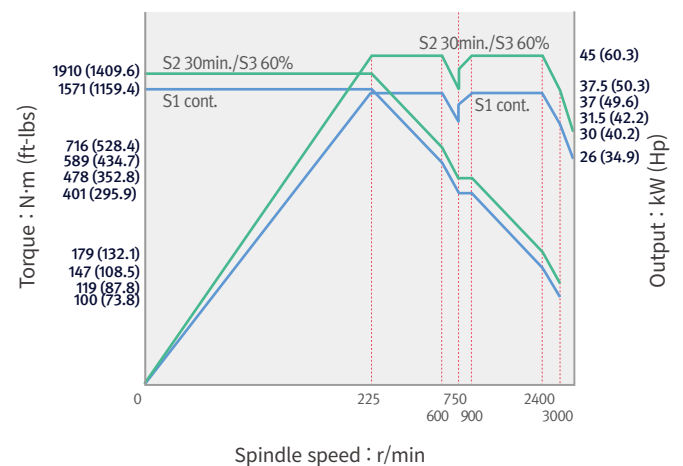

# DIMENSIONS

Units : mm (inch)

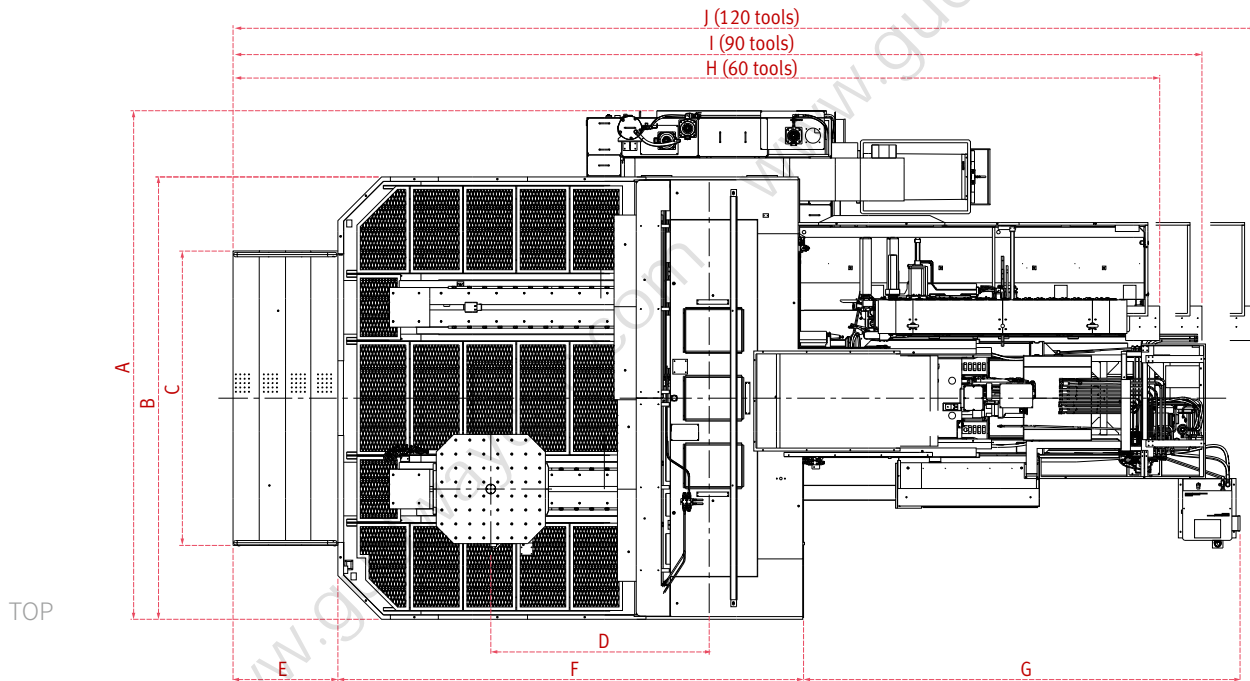

Model	A	B	C	D	E	F	G	H	I	J
GBH 1000	5822 (229.2)	5064 (199.4)	3370 (132.7)	2100 (82.7)	1162 (45.7)	4780 (188.2)	3715 (146.3)	9928 (390.9)	10411 (409.9)	11035 (434.4)
GBH 1250	5822 (229.2)	5064 (199.4)	3370 (132.7)	2500 (98.4)	1200 (47.2)	5330 (209.8)	4000 (157.5)	10530 (414.6)	11000 (433.1)	11623 (457.6)
GBH 1250W	5822 (229.2)	5064 (199.4)	3370 (132.7)	2500 (98.4)	1200 (47.2)	5330 (209.8)	4996 (196.7)	10606 (417.6)	11089 (436.6)	11713 (461.1)

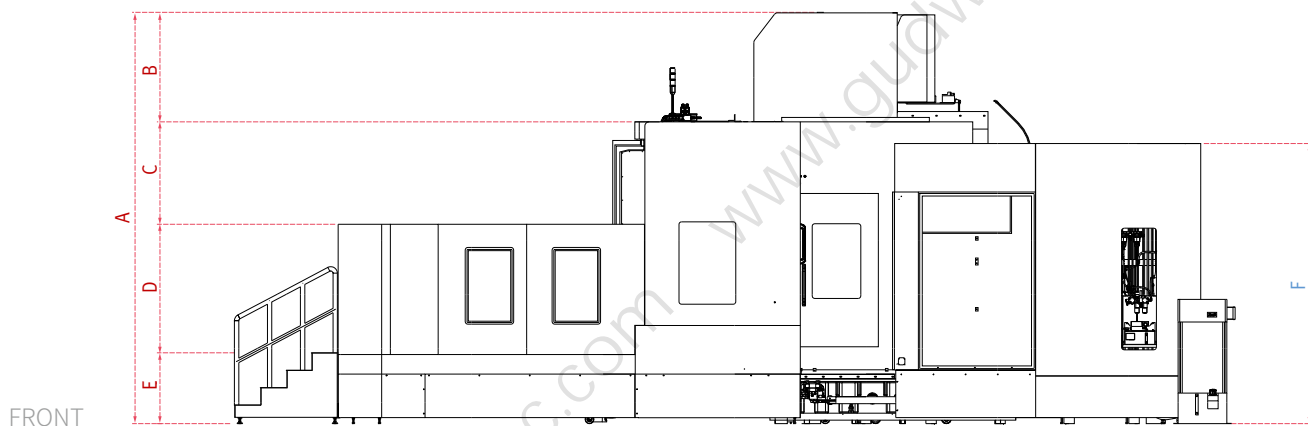

Model	A	B	C	D	E	F
GBH 1000	3885 (153.0)	660 (26.0)	929 (36.6)	1493 (58.8)	803 (31.6)	3225 (127.0)
GBH 1250	4130 (162.6)	660 (26.0)	1179 (46.4)	1493 (58.8)	803 (31.6)	3225 (127.0)
GBH 1250W	4581 (180.4)	1106 (43.5)	1179 (46.4)	1481 (58.3)	815 (32.1)	3225 (127.0)

\* Some peripheral equipment can be placed in other places

# TABLE DIMENSIONS | TOOL SHANK

## Table dimensions

Units : mm (inch)

TAP PALLET

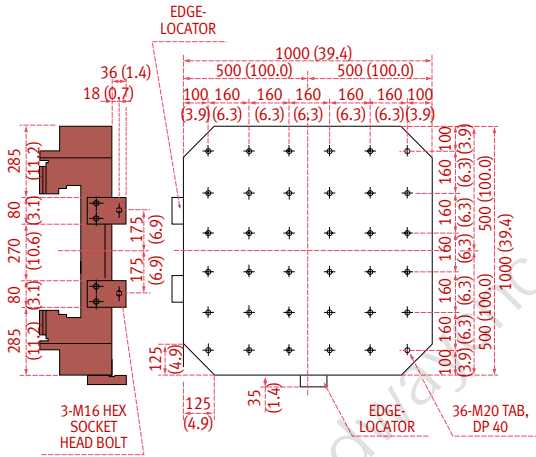

T - SLOT PALLET **option**

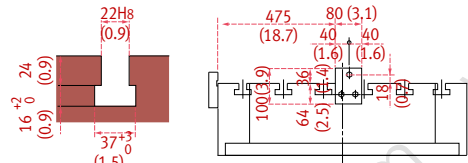
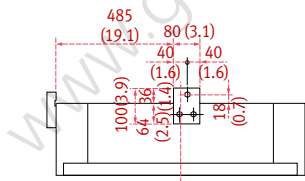
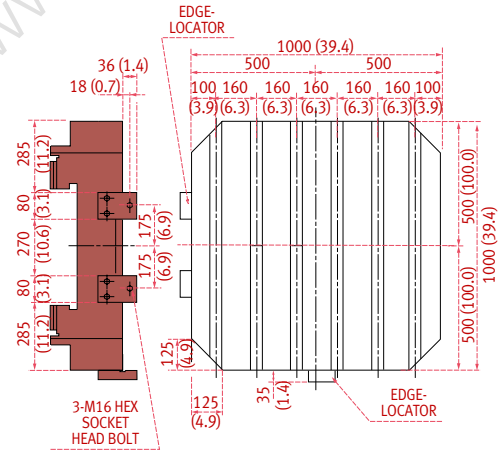

<T HOLE DETAIL>

## Tool Shank

Units : mm (inch)

BT 50

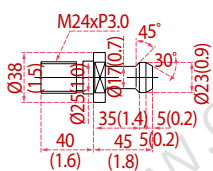
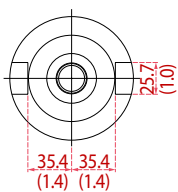
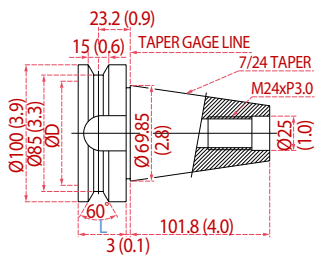

CAT 50

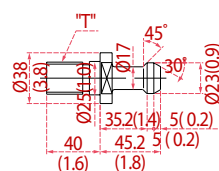
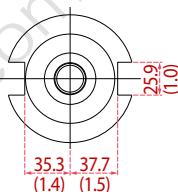
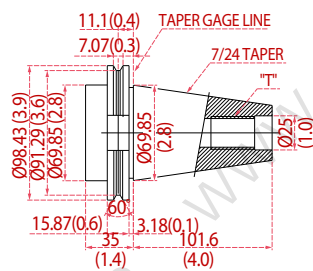

DIN 50

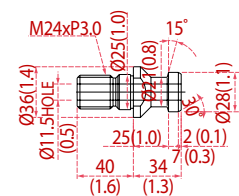
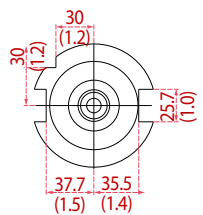
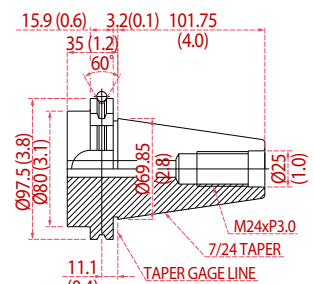



# MACHINE SPECIFICATIONS

Description		Unit	GBH 1000	GBH 1250	GBH 1250W
<b>Travels</b>	X-axis	mm (inch)		2100 (82.7)	
	Y-axis	mm (inch)	1250 (49.2)	1500 (59.1)	1400 (55.1)
	Z-axis	mm (inch)	1250 (49.2)	1500 (59.1)	1400 (55.1)
	W-axis	mm (inch)	-	-	300 (11.8)
<b>Table</b>	Distance from table top to spindle nose	mm (inch)	75 ~ 1325 (3.0 ~ 52.2)	50 ~ 1550 (2.0 ~ 61.0)	50 ~ 1450 (2.0 ~ 57.1)
	Table size	mm (inch)	1000 x 1000 {1250 x 1000} (39.4 x 39.4 {49.2 x 39.4})	1250 x 1250 {1250 x 1000} (49.2 x 49.2 {49.2 x 39.4})	
	Loading capacity	kg (lb)	3000 {5000} (6613.8 {11023.0})		5000 (11023.0)
	Table type	-	36-M20 x P2.5 {44-M20 x P2.5}	60-M2 x P2.5 {44-M20 x P2.5/ 36- M20 x P2.5}	
	Max. workpiece size (Ø x H)	mm (inch)	2000 X 1475 (78.7 X 58.1)		
<b>Spindle</b>	Max. spindle speed	r/min	6000 {6000 / 8000}		3000
	Taper	-	ISO #50, 7/24		
	Max. spindle torque	N·m (ft-lb)	1989.4 {3687 / 1410} (1468.2 {2721.0 / 1040.6})		1910 (1409.6)
	Spindle motor power	kW (Hp)	26 / 22 {37 / 30, 26 / 22} (34.9 / 29.5 {49.6 / 40.2, 34.9 / 29.5})		45 / 37 (60.3 / 49.6)
<b>Feedrate</b>	Rapid traverse rate (X/Y/Z/W)	m/min (ipm)	24 / 24 / 24 (944.9 / 944.9 / 944.9)		24 / 24 / 24 / 6 (944.9 / 944.9 / 944.9 / 236.2)
	Cutting feedrate	mm/min (ipm)	12000 (472.4)		
<b>ATC</b>	Type of tool shank	-	BT / CAT / DIN 50		
	Tool storage capacity	ea	60 {90 / 120 / 196 / 256 / 316}		
	Max. tool diameter (Neighboring pot empty)	mm (inch)	130 (300) (5.1{11.8})		
	Max. tool length	mm (inch)	650 (25.6)	650 {800*} (25.6 {31.5*})	700 (27.6)
	Max. tool weight	kg (lb)	30 (66.1)		
	Max. tool moment	N·m (ft-lb)	34.3 (25.3)		
	Method of tool selection	-	Fixed address		
	Tool change time (Tool-To-Tool)	sec	10		12
<b>Machine Dimensions</b>	Length x Width	mm (inch)	9657 x 5822 (380.2 / 229.2)	10530 x 5822 (414.6 / 229.2)	11526 x 5822 (453.8 / 229.2)
	Height	mm (inch)	3885 (153.0)	4130 (162.6)	4581 (180.4)
	Weight	kg (lb)	29000 (63933.1)	31000 (68342.3)	33000 (72751.5)
<b>CNC</b>	NC system	-	FANUC 31i Plus		
<b>Power source</b>	Electric power	kVA	71 {82, 68.5}		90

{ } : Option

\* In case of GBH 1250 with Max. Workpiece diameter 2000 mm spec.